

Adjusting Aluminium bracket boom in SL-frame

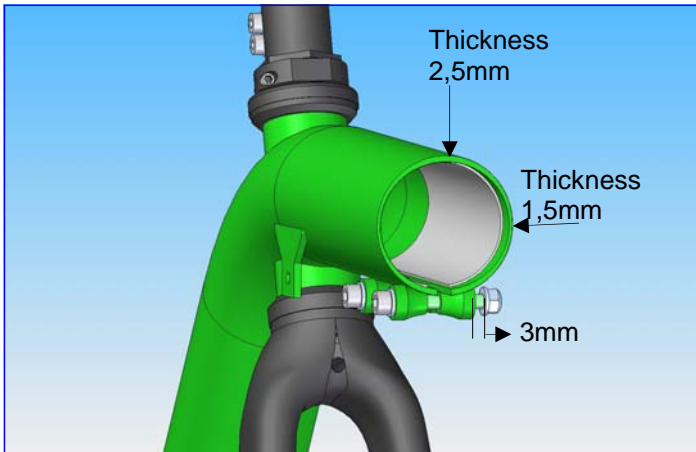

To check first:

1. Make sure you have a Challenge-SL tube (With variable wall thickness)
2. Make sure the filler tape is placed for the aluminium boom
3. Make sure the nuts have approximately 3 mm play
4. Check the bolts for the metal free paste against fretting

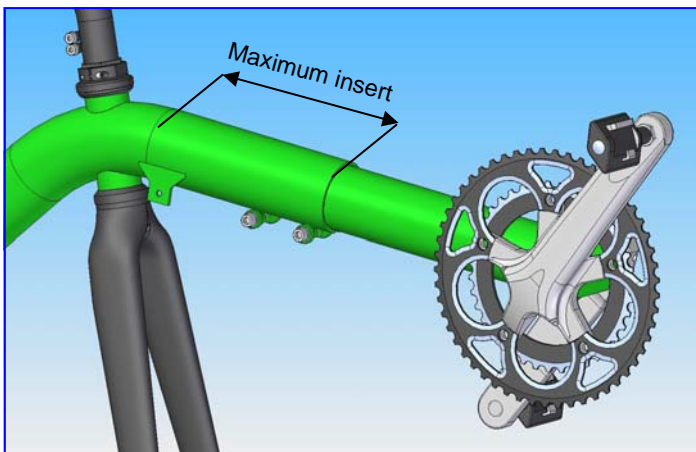

Pre-adjustment:

1. Place the boom in the tube and pre-adjust on your personal length
2. For new bikes the boom is mostly too long. Cut off when necessary
3. We advise to use the maximum insert minus 2 cm for fine adjustment

Note: It's better to cut several times a small piece, then cut one time too much.

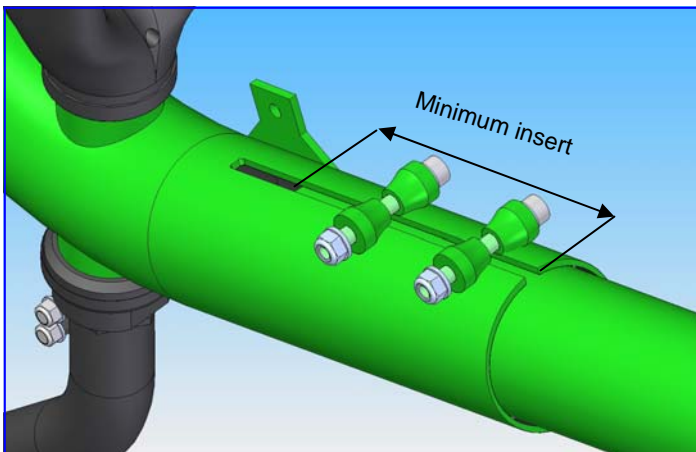

Fine adjustment:

1. Tighten the bolts with 1 Nm
2. Fine adjust the boom to your personal length
3. Make sure that the minimum insert is more than 12 cm

Note: Double check the minimum insert when you buy a used bike

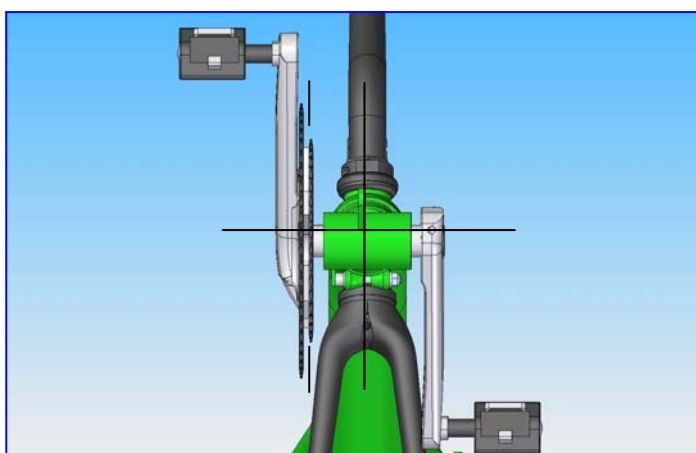

Alignment:

1. Align the boom. Use the chain wheels for reference
2. Tighten the bolts with 7 Nm